

Profile dryer unit mounted on frame

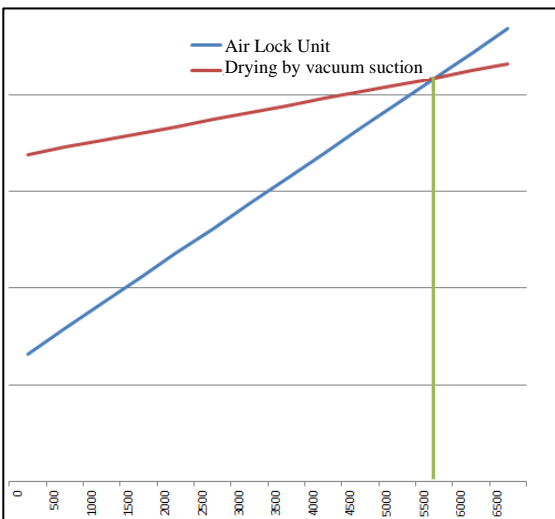

Break Even Point achieved after 5.500 h

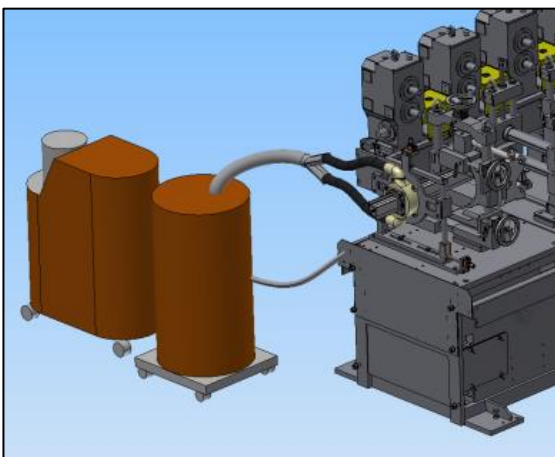

Complete system for profile drying

## Your Benefits of Drying by Vacuum Suction

- Dry liquid free profiles
- Avoiding oxidation of profiles (rust or white rust)
- Reliable welding process (no cooling lubricant drops in weld gaps)
- Very tight clearance to profile shape
- Easy to retrofit

## Comparing with Air Lock Units

- higher efficiency than compressed air units
- No generation of turbulence and fog by cooling lubricant
- Closed loop recirculation of cooling lubricant
- Amortisation of higher investment due to reduced energy consumption
- Reducing noise considerably

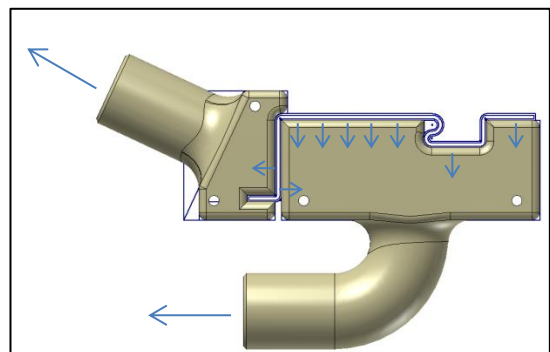

Part exposing optimised suction nozzle